

# Ambient Humidity & Temperature Sensor Module



Smart Agriculture, Smart Building, Smart Facility, Smart Farm, Smart Healthcare, Smart Retail, Smart Transportation

SKU: ATH



Safe Zone



Hazardous Zones

## AMBIENT HUMIDITY / TEMPERATURE SENSOR PROBES ATH

Ambient Humidity & Temperature Sensor Module ATH utilizes digital sensor delivers high accuracy measurement. Easy connect to WS433-M12(-T) via M12 connector.

### Applications

Automatic Ventilation System, Facility Monitoring, Indoor Air Quality Monitor, Warehouse Monitoring, Temperature Monitoring

### Notes For Applications



Humidity measuring range: 0 .. 100 %RH  
Humidity accuracy: +/- 2.0%

ATH-H1.PNG

- ✓ **Plug & Play**  
Just plug the pressure module onto WS433-M12F via M12 connector, then it works automatically
- ✓ **Multiple types**  
Compact type or cable extension type to suite variety applications
- ✓ **High accuracy**  
Digital sensor with factory-calibration
- ✓ **Sintered Filter**  
Alloy sintered filter to protect sensor in hash environment

## HUMIDITY SENSOR PROBE - P300



ATH-H2.PNG

## DAVITEQ TECHNOLOGIES INC

Ho Chi Minh City, VN | Koblenz, DE | Melbourne, AU | Zurich, CH

+84.28.6268.2523 / 6268.2524

info@daviteq.com

www.iot.daviteq.com

Created date: Dec-21-2022

Updated date: Aug-28-2024

1/4

## Specification

Sensor	Digital type, factory calibrated, output both Humidity & Temperature values
Humidity measuring range	0~100% RH
Humidity accuracy	±2.0%
Humidity resolution	0.1%
Temperature measuring range	-40~85°C
Temperature accuracy	±0.2°C
Temperature resolution	0.1°C
Sensor Filter	20µm Alloy sintered filter
Electrical connection	M12-male connector

### DAVITEQ TECHNOLOGIES INC

 Ho Chi Minh City, VN | Koblenz, DE | Melbourne, AU | Zurich, CH

 +84.28.6268.2523 / 6268.2524

 info@daviteq.com

[www.iot.daviteq.com](http://www.iot.daviteq.com)

Created date: Dec-21-2022

Updated date: Aug-28-2024

2/4

PROCESS HUMIDITY PROBE  
ATH-15



ATH-H3.PNG

DIMENSION DRAWING OF HUMIDITY PROBE P300-ATH  
(Unit: mm)

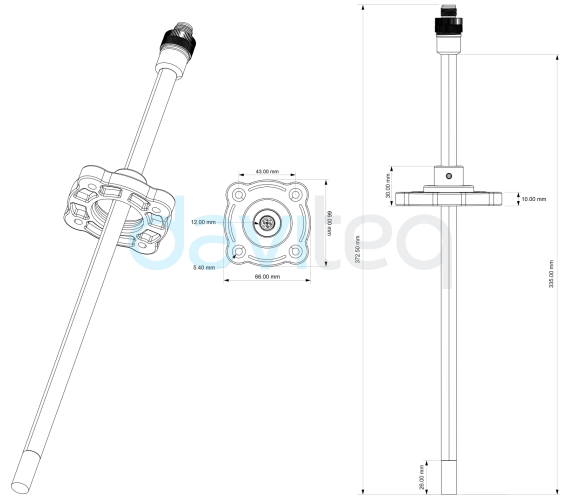

ATH-H4.PNG

DIMENSION DRAWING OF COMPACT HUMIDITY SENSOR

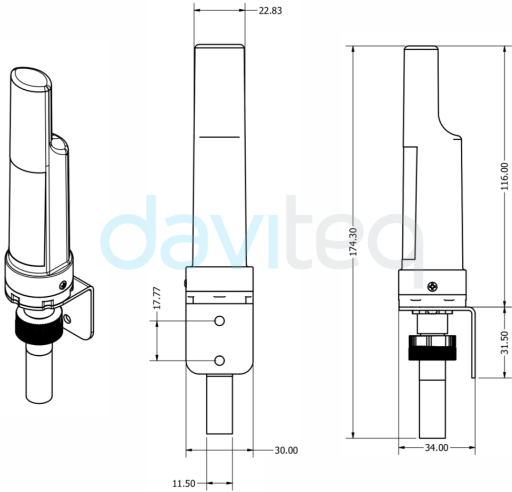

ATH-H5.PNG

DIMENSION DRAWING OF CABLE TYPE HUMIDITY SENSOR

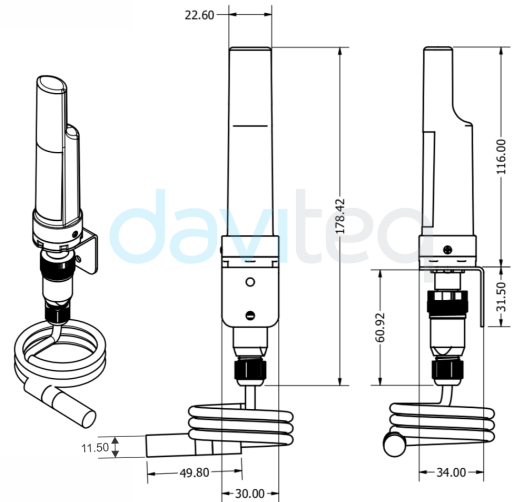

ATH-H6.PNG

DIMENSION DRAWING OF PROCESS HUMIDITY PROBE  
(Unit: mm)

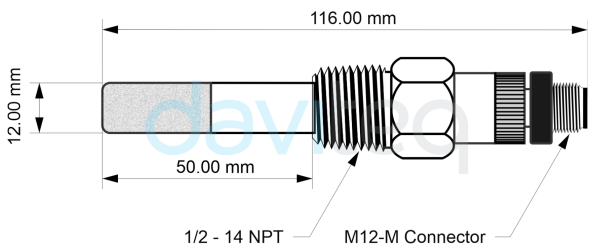

ATH-H7.PNG

RECOMMENDED BATTERIES FOR  
WIRELESS SENSOR WS433

E91 AA Alkaline battery

L91 AA Lithium battery



-18 .. + 60 oC working temperature

-40 .. + 60 oC working temperature

10-year shelf life

20-year shelf life

3000 mAh Capacity

3500 mAh Capacity

Price: 1X

Price: 3.5X

ATH-H8.PNG

DAVITEQ TECHNOLOGIES INC

Ho Chi Minh City, VN | Koblenz, DE | Melbourne, AU | Zurich, CH

+84.28.6268.2523 / 6268.2524

info@daviteq.com

www.iot.daviteq.com

Created date: Dec-21-2022

Updated date: Aug-28-2024

## Ordering Information

ITEM CODE	DESCRIPTIONS
ATH-11	Compact ambient Humidity & Temperature Sensor DULP module, M12-male connector
ATH-12-300	300mm Cable type ambient Humidity & Temperature Sensor DULP module, M12-male connector
ATH-12-P300	Ambient Humidity & Temperature Sensor DULP output, Rigid Sliding Probe 300mm length, Flange, M12-Male connector
ATH-15	Process Humidity & Temperature Sensor, Max 10barg, DULP output, L=50mm, 304SS, 1/2" NPT Male process connector, M12-male connector
Notes	* Sensor with extension cable may have length up to 2000mm, please consult factory.

### DAVITEQ TECHNOLOGIES INC

 Ho Chi Minh City, VN | Koblenz, DE | Melbourne, AU | Zurich, CH

 +84.28.6268.2523 / 6268.2524

 info@daviteq.com

[www.iot.daviteq.com](http://www.iot.daviteq.com)

Created date: Dec-21-2022

Updated date: Aug-28-2024

4/4