

Process Pressure Sensor Module



Smart Agriculture, Smart Building, Smart City, Smart Facility, Smart Farm, Smart Healthcare, Smart Utilities, Smart Transportation, Smart Factory

SKU: PPS

PROCESS PRESSURE SENSOR MODULE PPS-



GAUGE PRESSURE ABSOLUTE PRESSURE

RANGE : -1 .. + 35 BARG
OVER PRESSURE : 1.5X
ACCURACY : 0.5% OF SPAN
WORKING TEMPERATURE : -10 .. +80 oC

PPS-H1.PNG

Safe Zone

Hazardous Zones

Process Pressure Sensor Module PPS have different kind of measurement, such as Gage/ Absolute/ Differential, range -1~700 bar, high accuracy and stability, Ultra-low power consumption. Easy connect to WS433-M12(-T) via M12 connector.

Applications

Flood Monitoring, Fuel Monitoring, Level Monitoring, Process Monitoring, Safety Monitoring, Smart Irrigation, Water Pressure Pipeline Monitor

Notes For Applications

- Plug & Play**
Just plug the pressure module onto WS433-M12F via M12 connector, then it works automatically
- Multiple types of Pressure**
Gage/ Absolute/ Differential
- High accuracy**
0.5% of span
- Wide measurement range**
Select from -1~700 bar

DIMENSION DRAWINGS OF PRESSURE SENSOR WITH WIRELESS MODULE

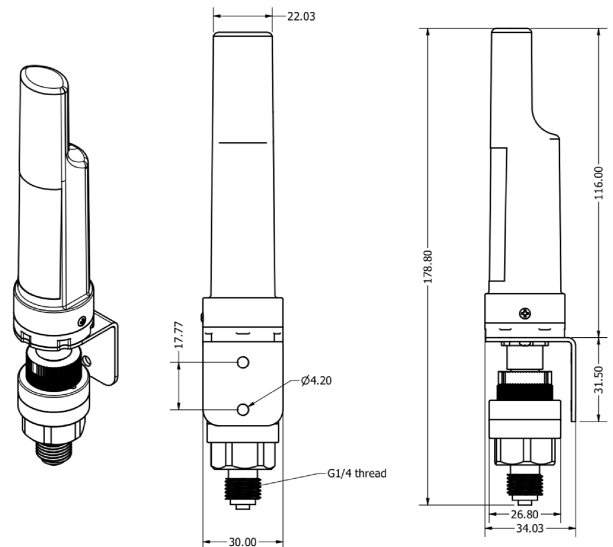

PPS-H5.PNG

DAVITEQ TECHNOLOGIES INC

Ho Chi Minh City, VN | Koblenz, DE | Melbourne, AU | Zurich, CH

+84.28.6268.2523 / 6268.2524

info@daviteq.com

www.iot.daviteq.com

Created date: Dec-21-2022

Updated date: Aug-28-2024

1/4

Specification

Sensing Technology	Advanced PIEZO/Capacitance technology
Measuring range	Select from -1~35 bar Gage/Absolute/Sealed Gage
Over pressure protection	1.5 x Span
Accuracy	0.5% of span
Stability	< 0.3% span/year
Wetted parts	304SS/316SS
Measuring Fluids	Any fluid which is workable with materials 304SS/316SS
Working temperature	-10~80°C
Process connection	Standard G 1/4 or Others (consult factory)
Electrical connection	M12-male connector

DAVITEQ TECHNOLOGIES INC

 Ho Chi Minh City, VN | Koblenz, DE | Melbourne, AU | Zurich, CH

 +84.28.6268.2523 / 6268.2524

 info@daviteq.com

www.iot.daviteq.com

Created date: Dec-21-2022

Updated date: Aug-28-2024

2/4

CONNECT WITH IoT GATEWAY



LEET-M-H3.PNG

CONNECT WITH WIRELESS TRANSMITTER



LEET-M-H4.PNG

PRODUCT PACKAGE



LEET-M-H5.PNG



LEET-M-H6.PNG

DIMENSION DRAWINGS

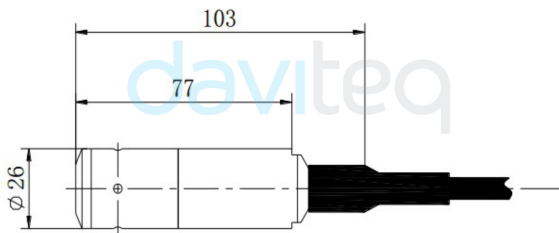

LEET-M-H7.PNG

WIRING

FLYING LEADS

Wire color	Connection
Black	+V
Red	0V/+OUT

M12-F CONNECTOR



LEET-M-H8.PNG

DAVITEQ TECHNOLOGIES INC

Ho Chi Minh City, VN | Koblenz, DE | Melbourne, AU | Zurich, CH

+84.28.6268.2523 / 6268.2524

info@daviteq.com

www.iot.daviteq.com

Created date: Dec-21-2022

Updated date: Aug-28-2024

Ordering Information

ITEM CODE	DESCRIPTIONS
PPS-G-10	Gage Pressure Sensor DULP Module, range 0-10 barg, accuracy 0.5%, process connection G 1/4-male, 304SS, electrical connector M12-male
Notes	* It is possible to use extension M12 cable with max 1.0m lenght for connecting between sensor module and wireless transmitter.

DAVITEQ TECHNOLOGIES INC

 Ho Chi Minh City, VN | Koblenz, DE | Melbourne, AU | Zurich, CH

 +84.28.6268.2523 / 6268.2524

 info@daviteq.com

www.iot.daviteq.com

Created date: Dec-21-2022

Updated date: Aug-28-2024

4/4