

Wireless PT100 Temperature Sensor



Smart Agriculture, Smart Building, Smart City, Smart Energy, Smart Facility, Smart Factory, Smart Farm, Smart Retail, Smart Utilities

SKU: WS433-PT100

WIRELESS PT100 TEMPERATURE SENSOR WS433-PT100



WS433-PT100-H1.PNG



Wireless PT100 Temperature Sensor WS433-PT100 is wireless sensor with modular design connected to PT100 temperature sensor via PT100 sensor converter cable with M12 connector, it utilizes Digital temperature sensor delivers high accuracy measurement in range 0~100°C. The wireless transmitter is Sub-GHz technology from Texas Instruments allows long range transmission at ultra-low power consumption. It will connect 2-way wirelessly to the wireless coordinator WS433-CL to send data and receiving the configuration. It can be configured the operation parameters like data sending interval, health check cycle... remotely from Globiots platform or via ModbusRTU software (thru the WS433-CL). Its default data rate is 50kbps, can be switched to 625bps to increase the communication range. It can last up to 10 years with a single AA battery. There are a lot of applications as environment monitoring for factories, agriculture, boilers, ...

Applications

Temperature Monitoring, Process Monitoring, Safety Monitoring

Notes For Applications

- ✓ **Reliable & Secured Wireless Connection**
Sub-GHz technology from Texas Instruments allows reliable wireless connection and secured data by AES-128
- ✓ **10-year with a single battery**
Ultra-low power sensing technology from Daviteq with Ultra-low power wireless technology from Texas Instruments allow the sensor can last up to 10 years with a single battery AA.
- ✓ **High accuracy**
Sensors are pre-calibrated at factory to deliver high accuracy and quick installation
- ✓ **IP67 Weather-proof**
Wireless transmitter with IP67 design for for both Indoor and Outdoor applications

CONNECT WITH PT100 TEMPERATURE SENSOR

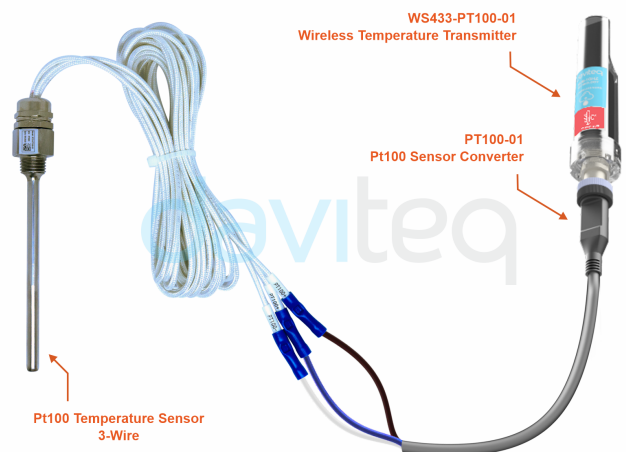

WS433-PT100-H2.PNG

DAVITEQ TECHNOLOGIES INC

Ho Chi Minh City, VN | Koblenz, DE | Melbourne, AU | Zurich, CH

+84.28.6268.2523 / 6268.2524

info@daviteq.com

www.iot.daviteq.com

Created date: Dec-21-2022

Updated date: Aug-28-2024

1/4

Specification

Input	Pt100 Temperature Sensor
Accuracy	0.05%
Sensor port connector	M12-Female Connector
Accessories	Pt100 sensor converter cable 0.5m length with M12-Male connector (not include)
Data speed	Up to 50kbps
Tranmission distance, LOS	500m
Antenna	Internal Antenna, 3 dbi
Battery	01 x AA 1.5VDC, up to 10-year operation, depends on configuration
Frequency Band	ISM 433MHz, Sub-GHz technology from Texas Instrument, USA
International Compliance	ETSI EN 300 220, EN 303 204 (Europe) FCC CFR47 Part15 (US), ARIB STD-T108 (Japan)
Security Standard	AES-128
Operating temperature of PCB	-40~60°C (with AA L91 Energizer®)
Housing	Poly-carbonate, IP67
Installation method	L-type bracket SUS304 , by M4 screws or double-sided 3M tape (included)
Product dimensions	125x30x30mm
Net weight (without battery)	< 60g
Box dimension	190x50x50mm
Gross weight	100g

DAVITEQ TECHNOLOGIES INC

 Ho Chi Minh City, VN | Koblenz, DE | Melbourne, AU | Zurich, CH

 +84.28.6268.2523 / 6268.2524

 info@daviteq.com

www.iot.daviteq.com

Created date: Dec-21-2022

Updated date: Aug-28-2024

2/4

CONNECT WIRELESS SENSORS TO any PLC, HMI, SCADA or IoT Platform

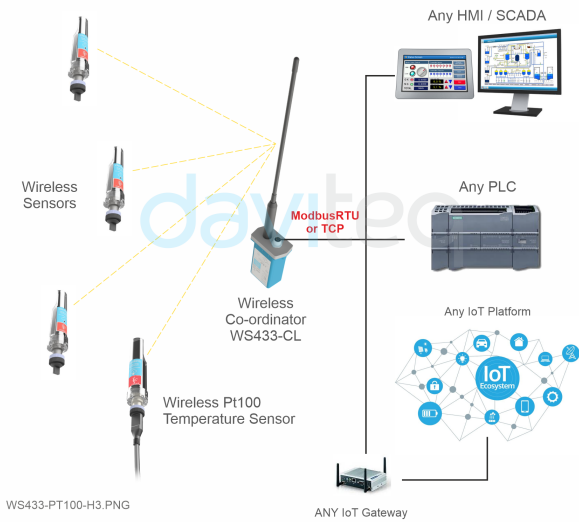

CONNECT WIRELESS SENSORS TO GLOBIOTS Platform

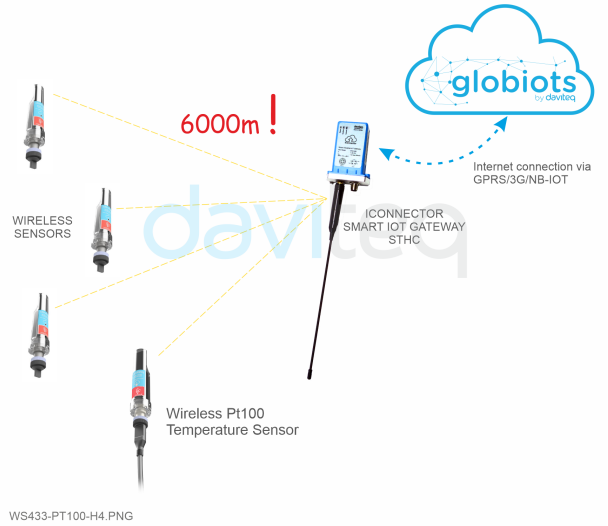

WIRING THE PT100 TEMPERATURE SENSOR

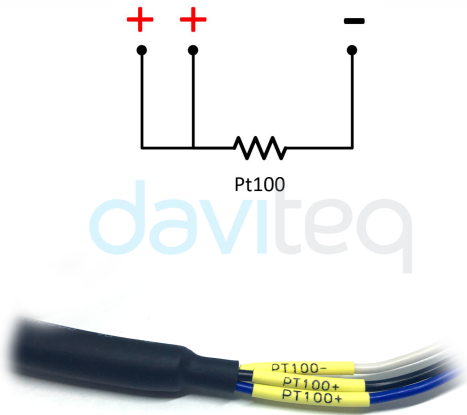

DIMENSION DRAWINGS OF WS433 SENSOR WITH CABLE OUTPUT

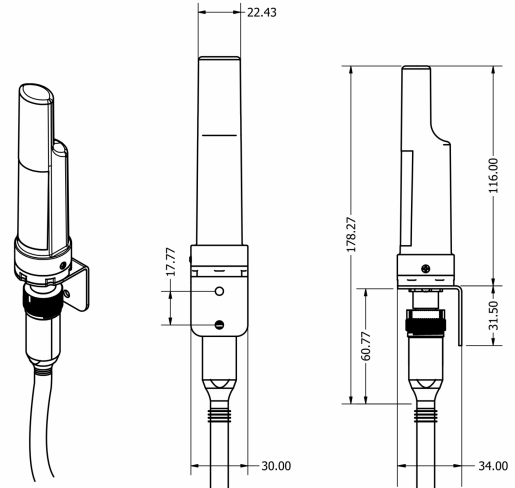

CARTON BOX OF WIRELESS SENSOR



RECOMMENDED BATTERIES

E91 AA Alkaline battery

L91 AA Lithium battery



-18 .. + 60 oC working temperature

-40 .. + 60 oC working temperature

10-year shelf life

20-year shelf life

3000 mAh Capacity

3500 mAh Capacity

Price: 1X

Price: 3.5X

WS433-PT100-H8.PNG

DAVITEQ TECHNOLOGIES INC

Ho Chi Minh City, VN | Koblenz, DE | Melbourne, AU | Zurich, CH

+84.28.6268.2523 / 6268.2524

info@daviteq.com

www.iot.daviteq.com

Created date: Dec-21-2022

Updated date: Aug-28-2024

Ordering Information

ITEM CODE	DESCRIPTIONS
WS433-PT100-01	Wireless PT100 Temperature Sensor 433MHz, Internal antenna, Type AA battery 1.5VDC, IP67
ACCESSORIES	undefined
PT100-01	Pt100 Sensor Converter 0.5m length with M12-Male connector
Notes	* Purchase Pt100 Sensor Converter to connect Pt100 with Wireless Sensor

DAVITEQ TECHNOLOGIES INC

 Ho Chi Minh City, VN | Koblenz, DE | Melbourne, AU | Zurich, CH

 +84.28.6268.2523 / 6268.2524

 info@daviteq.com

www.iot.daviteq.com

Created date: Dec-21-2022

Updated date: Aug-28-2024

4/4