

NB-IoT Ex d Process Pressure Sensor



Smart Energy, Smart Facility, Smart Factory, Smart Utilities

SKU: WSNBEX-PPS

Ex d approved NB-IoT Process Pressure Sensor WSNBEX-PPS-G10



WSNBEX-PPS-G10-H1.JPG



Safe Zone

Hazardous Zones

WSNBEX-PPS is the LTE Cat M1/ NB1 Integrated Process Pressure Sensor with Ex d approval for installation in Zone 1, Zone 2 or Safe Zone, and it has different kinds of measurements, such as Gage/ Absolute/ Sealed Gage, range 0~1380 bar, high accuracy, and stability. With Ultra-low-power design and smart firmware allow the sensor can last up to 10 years with a single D battery (depends on configuration). It can support all frequency bands in the World. The main protocol is MQTT/MQTTS, it supports all the common MQTT brokers like Mosquitto, EMQX, HiveMQ...

Typical applications are pressure monitoring of oil pipelines, gas pipelines, LPG tanks, CNG tanks, etc.

Applications

Oil & Gas Pipeline Monitor, Process Monitoring, Safety Monitoring

Notes For Applications

Sensor Materials Compatibility: Choose materials that won't react with the substances or degrade in corrosive media. **Environmental Conditions:** Consider the system environment (pipes, vibrations, temperature, etc.). **Pressure Range:** Choose sensors that function well within the process range. **Precision and Sensitivity:** Determine the required level of precision and sensitivity.

Connected by LTE Cat M1/ NB1
Support Global bands for LTE Cat M1 and NB1

10 Year battery
Ultra-low power sensing technology from Daviteq with Ultra-low power wireless technology allows the sensor can last up to 10 years with a single battery D

High Accuracy & Stable
Advanced Piezo technology to deliver high accuracy and stable measurement

Ex d Designs
Ex d approval for installation in Zone 1, Zone 2 or Safe Zone

PRESSURE SENSOR INSTALLED ON THE GAS PIPE

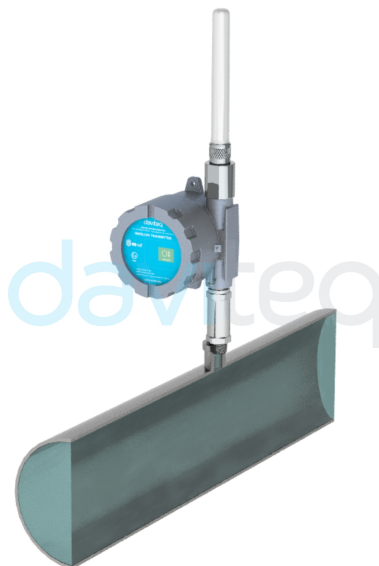

WSNBEX-PPS-G10-H2.JPG

DAVITEQ TECHNOLOGIES INC

Ho Chi Minh City, VN | Koblenz, DE | Melbourne, AU | Zurich, CH

+84.28.6268.2523 / 6268.2524

info@daviteq.com

www.iot.daviteq.com

Created date: Dec-21-2022

Updated date: Apr-15-2026

Specification

Sensor	Advanced Piezo technology
Measurement range	Select from 0~1380 bar Gage/ Absolute/ Sealed Gage
Burst Pressure	8 x range (max 2000 barg)
Accuracy & Stability	0.2% of span, 0.1% span/ year for range from 400mbarg to 1380barg
Temperature Drift	Typically 0,2% / 10°C Max 0,3% / 10°C
Thermal compensation range	-10...80°C
Hysteresis, repeatability	0.05%
Wetted parts & Measuring Fluids	316SS or Hastelloy C 276, Any fluid which is workable with those materials
Process Working temperature	-40~130°C
Process connection	½" NPT-male as standard, others please consult factory
COMMUNICATION	
Connectivity	LTE Cat M1/ NB1 for B1, B2, B3, B4, B5, B8, B9, B10, B12, B13, B17, B18, B19, B20, B25, B26, B27, B28, B66
	Fall back Quad-band GPRS/ GSM 850, 900, 1800, 1900
Antenna	N-male type external Antenna
Protocol	MQTT, MQTTs, supports all common MQTT brokers
Battery	1 x D Type LiSOCl ₂ , working time up to 10 years (depends on configuration). The battery is not included.
ATEX Certificates	FTZU 03 ATEX 0207U, TÜV CY 18 ATEX 0206158 X, KDB 18 ATEX 0055X
Marking	ATEX II2G Ex db IIC Gb, II2D Ex tb IIIC Db
	II 2(1) G Ex db mb [Ia Ga] IIA/IIB/IIC T5..T6 Gb, II 2(1) D Ex mb tb [Ia Da] IIIC T80°C..T100°C Db
	II 2G Ex db IIC T6/T5/T4 Gb, II 2D Ex tb IIIC T85°C/T100°C/T120°C Db
IECEX Certificates	FTZU 12.0017U, MSC 19.0001X, KDB 18.0005X
Marking	Ex db IIC Gb, Ex tb IIIC Db
	Ex db mb [Ia Ga] IIA/IIB/IIC T5..T6 Gb, Ex mb tb [Ia Da] IIIC T80°C..T100°C Db
	Ex db IIC T6/T5/T4 Gb, Ex tb IIIC T85°C/T100°C/T120°C Db
Applicable zones	Zone 1 - 21 (gas) and Zone 2 - 22 (dust)
Ambient working temperature	-40~85°C
Housing	Cast aluminium, powder coated, IP67, wall mounting holes
Product dimensions	W123 x D106 x H406 mm (with antenna)
Net weight	< 2.5kg
Packaging dimension	W150 x D150 x H250 mm
Gross weight	< 2.6kg

DAVITEQ TECHNOLOGIES INC

📍 Ho Chi Minh City, VN | Koblenz, DE | Melbourne, AU | Zurich, CH

☎ +84.28.6268.2523 / 6268.2524

✉ info@daviteq.com

www.iot.daviteq.com

Created date: Dec-21-2022

Updated date: Apr-15-2026

DIMENSION DRAWING OF WSNBEX-PPS
(Unit: mm)

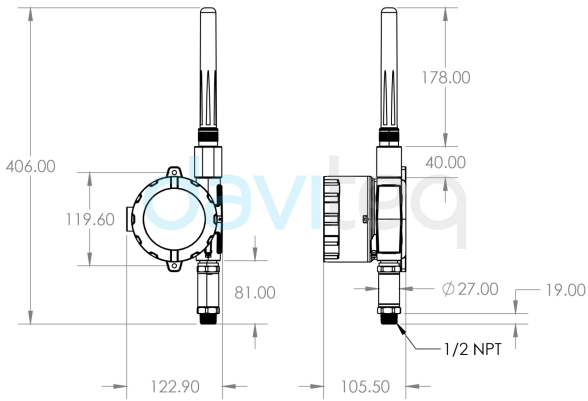

WSNBEX-PPS-G10-H3.JPG

RECOMMENDED BATTERIES FOR WSNBEX-PPS

LS 33600 Lithium battery



-60°C..+85°C working temperature

Low self-discharge rate

17.0 Ah Capacity

WSNBEX-PPS-G10-H4.JPG

DAVITEQ TECHNOLOGIES INC

Ho Chi Minh City, VN | Koblenz, DE | Melbourne, AU | Zurich, CH

+84.28.6268.2523 / 6268.2524

info@daviteq.com

www.iot.daviteq.com

Created date: Dec-21-2022

Updated date: Apr-15-2026

Ordering Information

ITEM CODE	DESCRIPTIONS
WSNBEX-PPS-G10-01	LTE Cat M1, NB1 Process Pressure Sensor, Ex d, IP67, 0-10 barg, 316SS, 1/2"NPT
WSNBEX-PPS-G10-02	LTE Cat M1, NB1 Process Pressure Sensor, Ex d, IP67, 0-10 barg, 316SS, 1/4"NPT
Notes:	Select other pressure ranges: 1, 1.6, 2.5, 4, 6, 10, 16, 25, 40, 60, 100, 160, 250, 400, 600, 1000 BARG.

DAVITEQ TECHNOLOGIES INC

 Ho Chi Minh City, VN | Koblenz, DE | Melbourne, AU | Zurich, CH

 +84.28.6268.2523 / 6268.2524

 info@daviteq.com

www.iot.daviteq.com

Created date: Dec-21-2022

Updated date: Apr-15-2026